

AUSGANGSLAGE  
ROBUSTER STÄDTEBAU

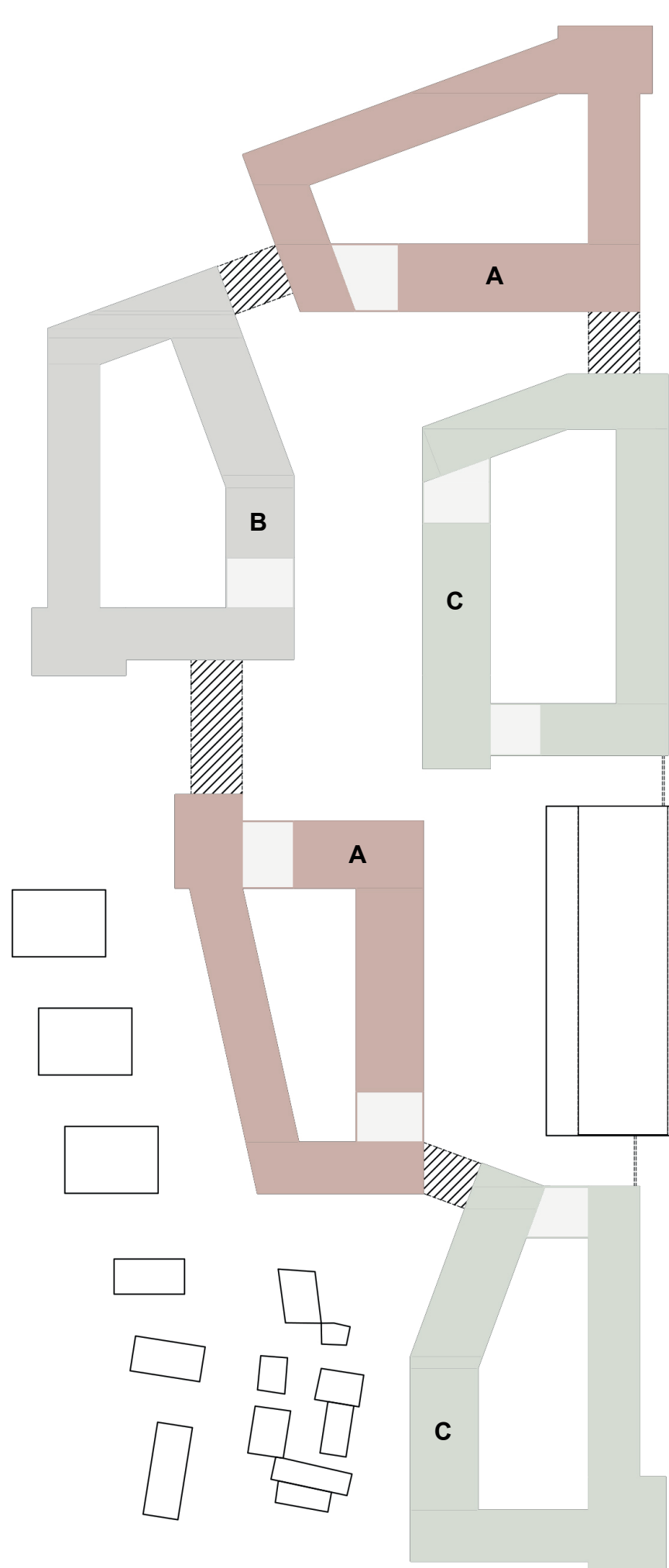

SZENARIO 1  
AUSFÜHRUNG DURCH  
DREI VERSCHIEDENE  
ARCHITEKTEN

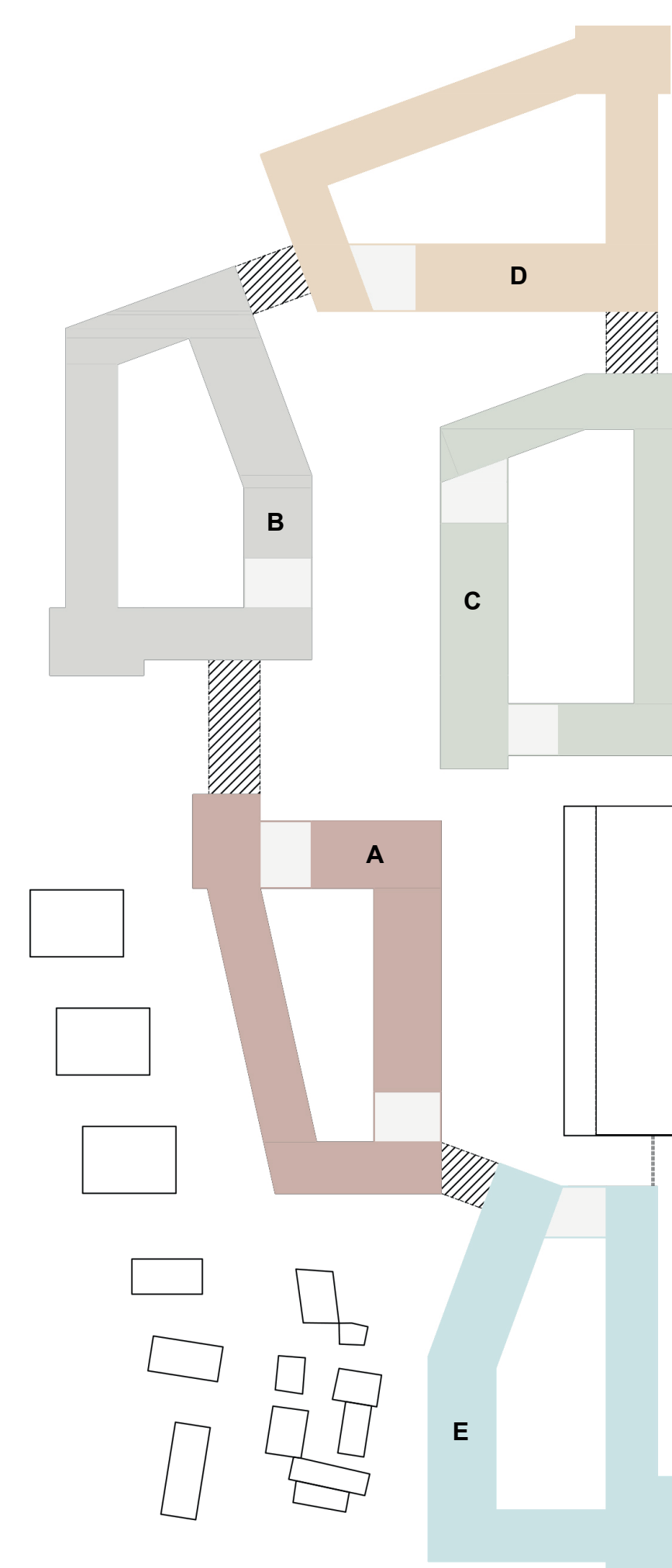

SZENARIO 2  
AUSFÜHRUNG DURCH  
FÜNF VERSCHIEDENE  
ARCHITEKTEN

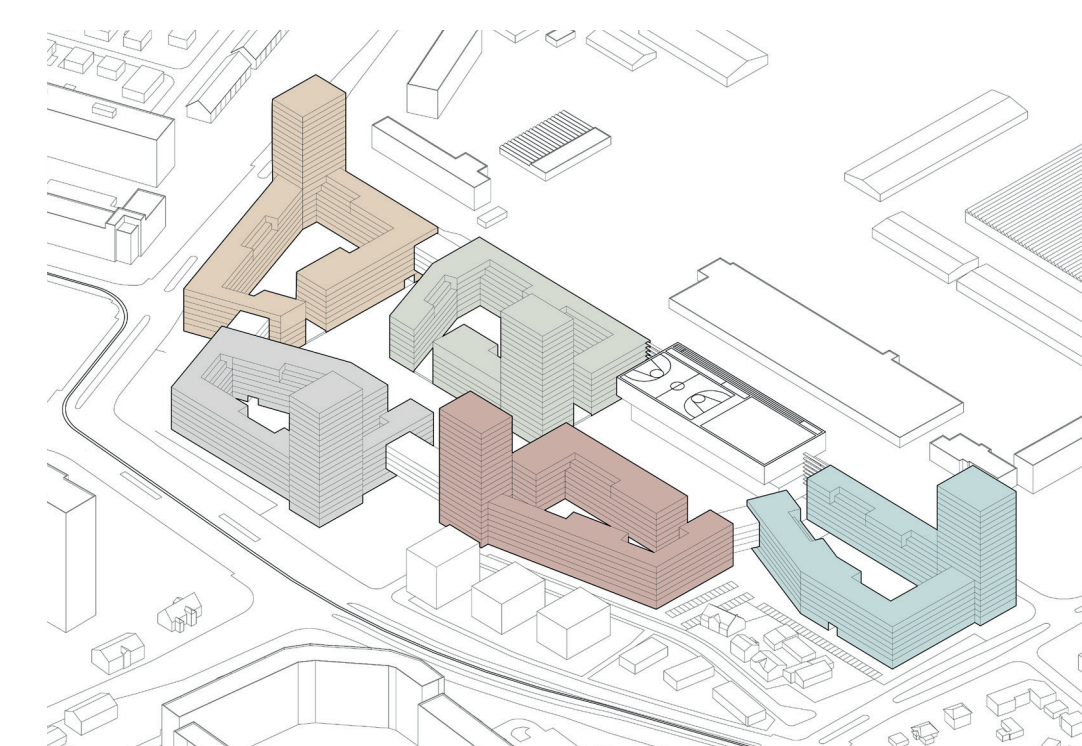
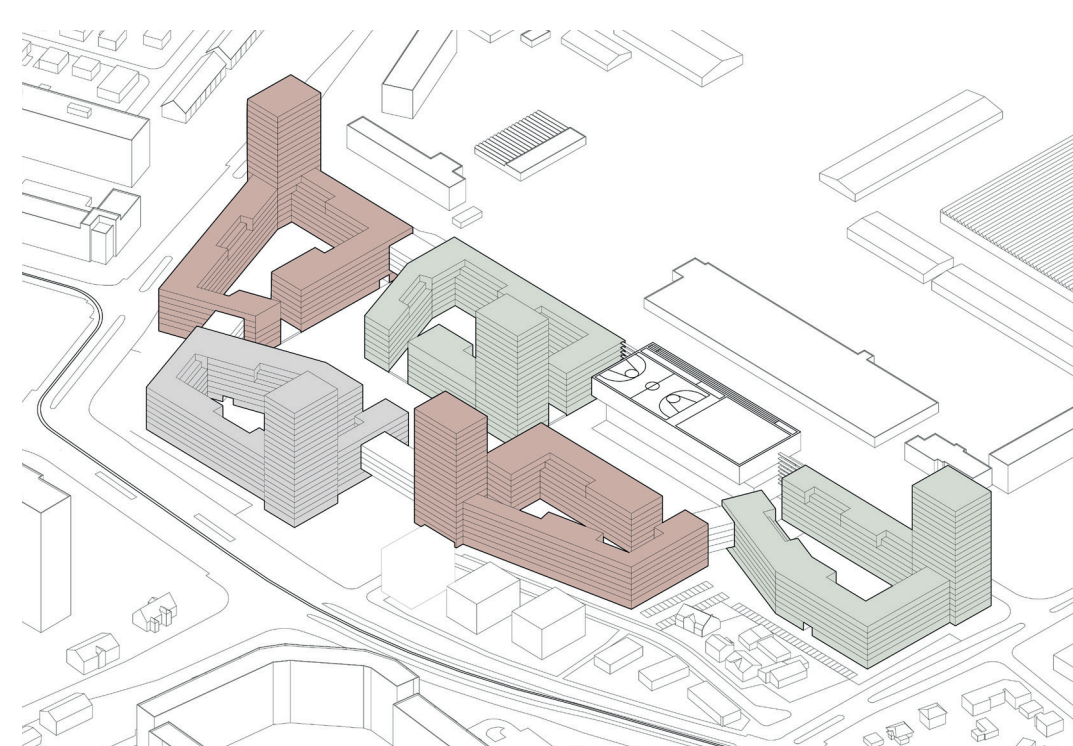
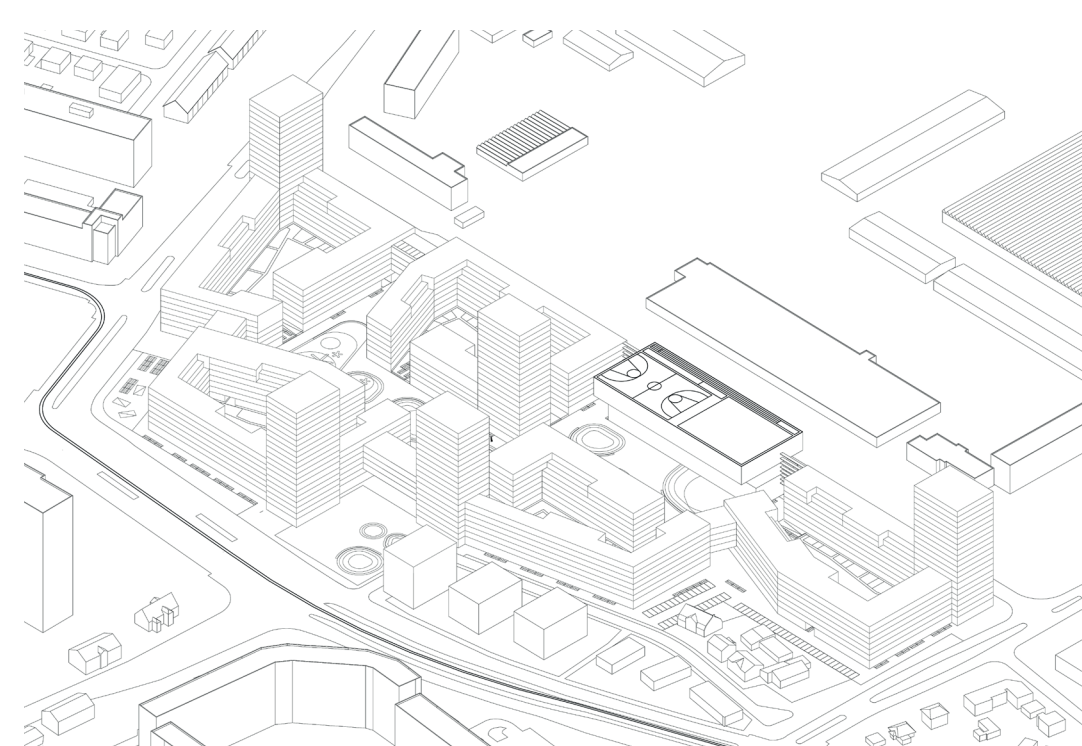

GESTALTUNGSREGELN - MÖGLICHE VARIANTEN DER AUSFÜHRUNG DURCH VERSCHIEDENE ARCHITEKTEN

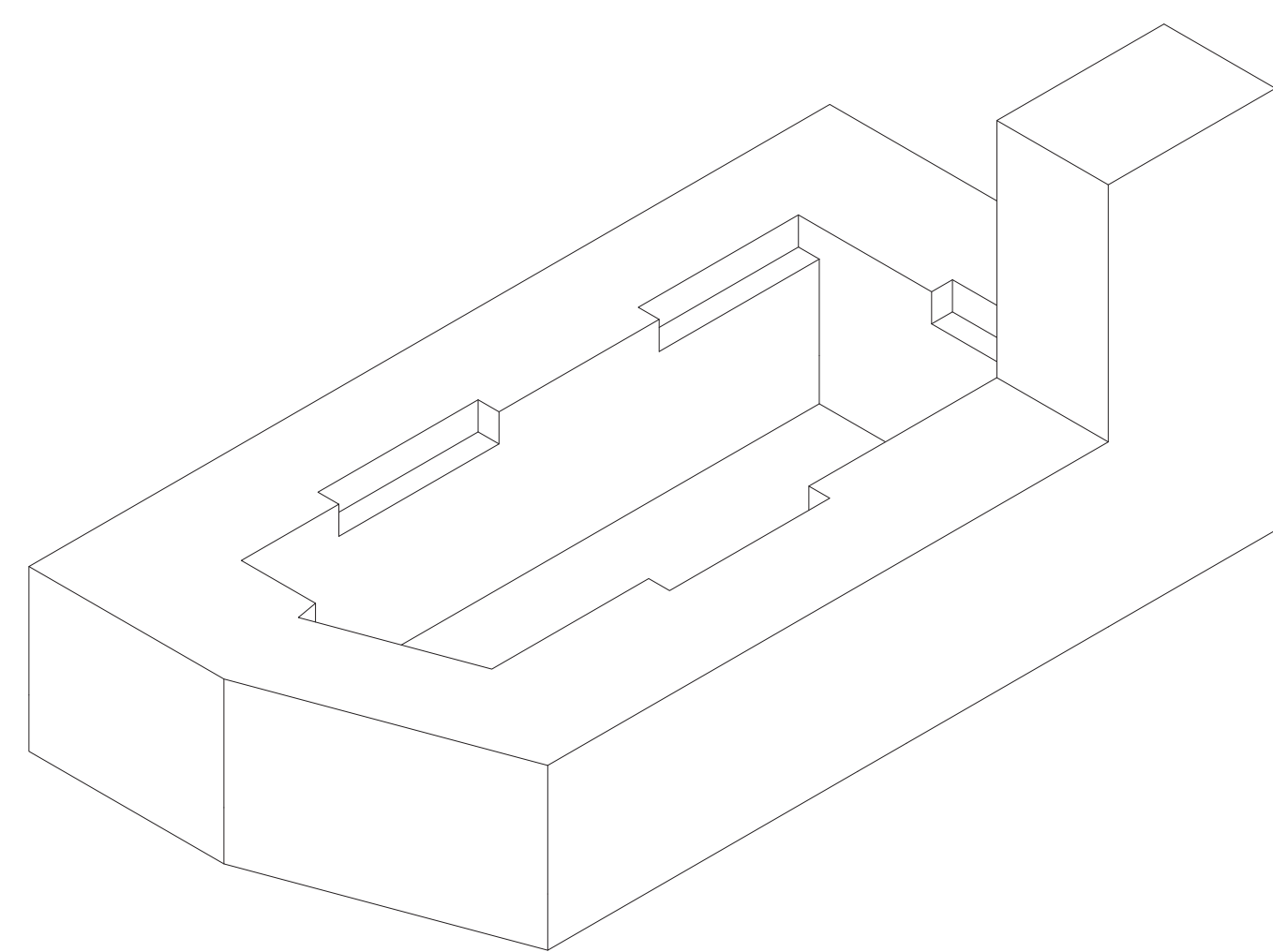

VARIANTE 1  
EINFACHE STAFFELUNG 7.OG

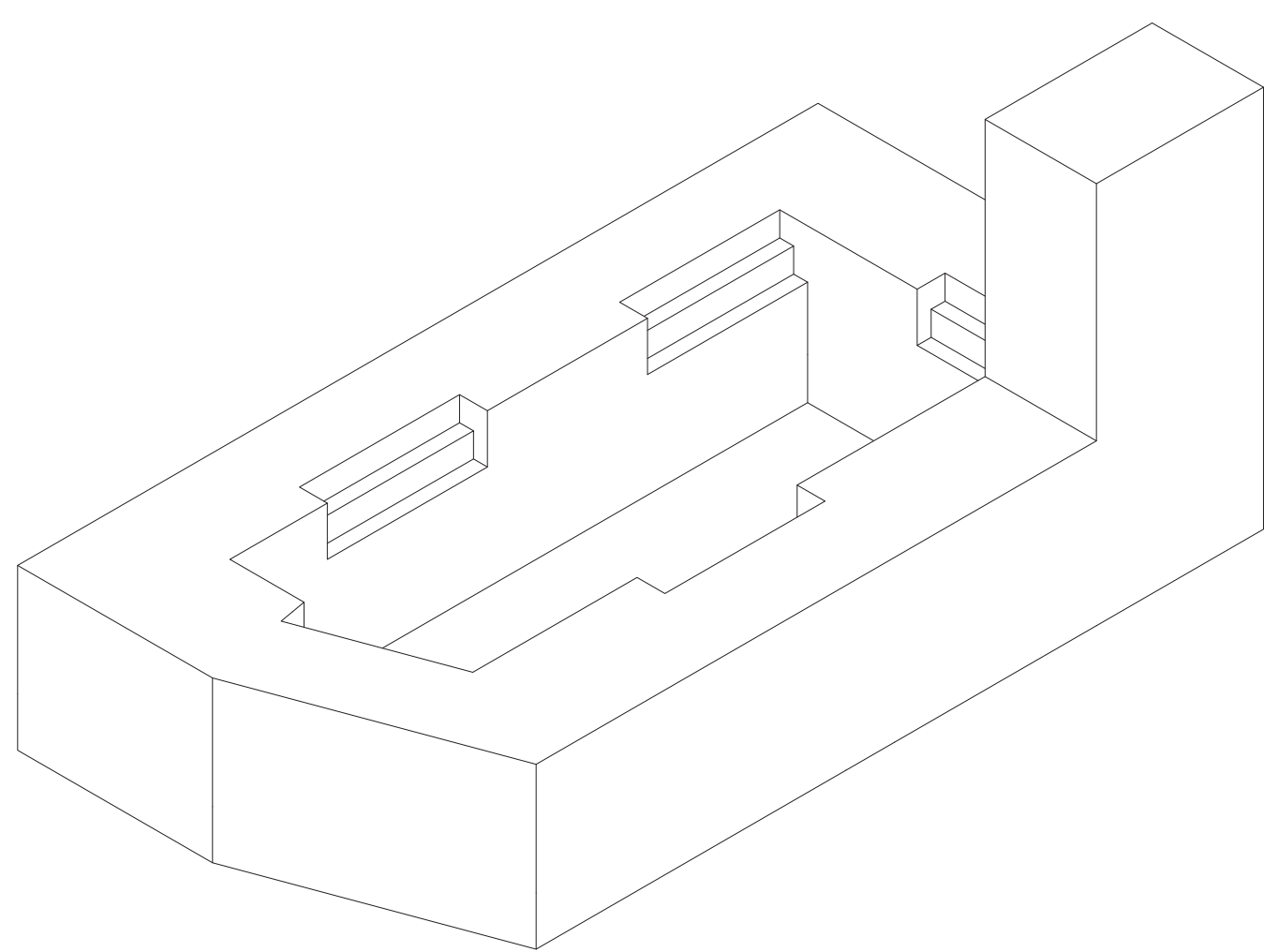

VARIANTE 2  
PUNKTUELLE DOPPELSTAFFELUNG 6./7.OG

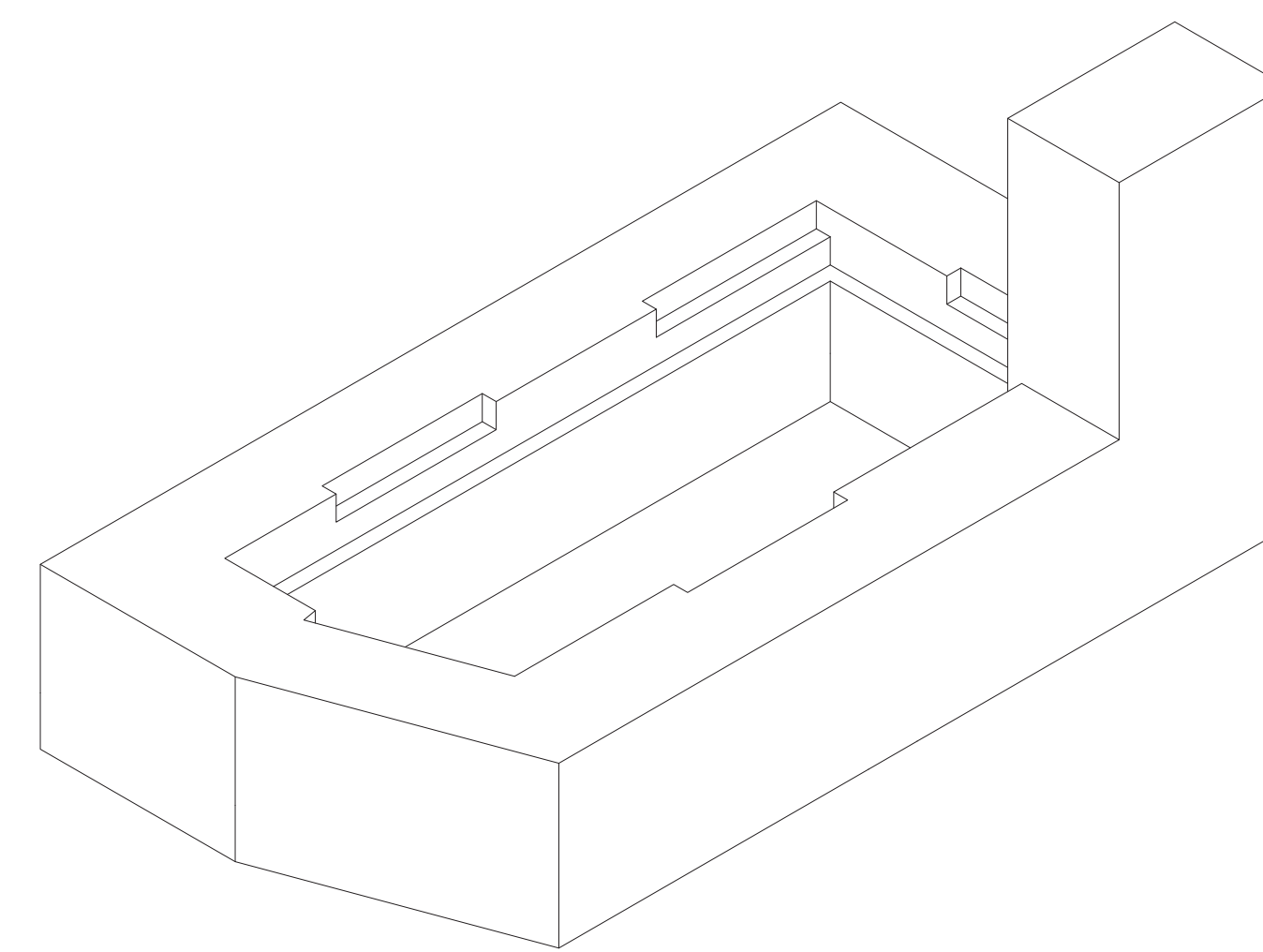

VARIANTE 3  
LINEARE STAFFELUNG 6.OG  
PUNKTUELLE STAFFELUNG 7.OG

GESTALTUNGSREGELN - MÖGLICHE VARIANTEN DER INNENHOFSTAFFELUNG

